

The Australian designed and manufactured, **Autoflo Wall Mount AA2-MH** Mains Power Sensor Tap is suitable for hand-washing applications, particularly in the food service, hospitality and health industries where a reliable and affordable hands free sensor tap is of paramount importance for prevention of cross-contamination, hygiene and water saving.

The **Autoflo Wall Mount AA2-MH** is a built for purpose product, with clever features incorporated. The electronics are designed so the water flow is set to run for a period after the hands are removed from the sensor area, as is required in hospitals. The stainless steel sensor plate is sized so as to be mountable on the wall, or an electrical block. Adjustable sensor range and run-time ensure consistent performance in demanding environments.

## FEATURES

- Sensor range adjustable
- Run-time adjustment after hands are removed from sensor area
- Elegant chrome straight spout
- Stainless steel sensor plate
- Sensor operation indicator LED
- Power Pack operation indicator LED
- Removable solenoid filter basket
- Simple installation



**Order Code: 100-0177**

## TYPICAL DIMENSIONS

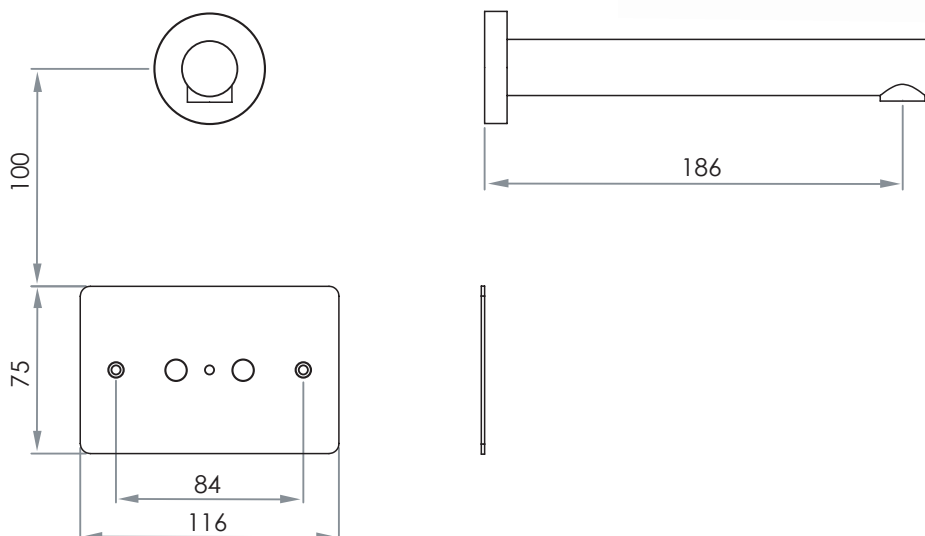

Every effort is made to ensure specifications are correct at the time of printing. Autoflo Pty Ltd reserves the right to make changes without prior notice. All measurements shown are in millimetres.

Proudly distributed by



### TECHNICAL SPECIFICATIONS

- SENSOR TYPE - Active Infrared
- SENSOR RANGE - 180mm factory set
- OPERATING SUPPLY - 24v AC Power Pack
- OPERATING PRESSURE - 50 to 500kPa
- RUN TIME - Max 15 seconds after hands removed
- FLOW RATING - 7 litres per minute
- SOLENOID - 24V
- MAX TEMPERATURE - 50°C



### TYPICAL INSTALLATION

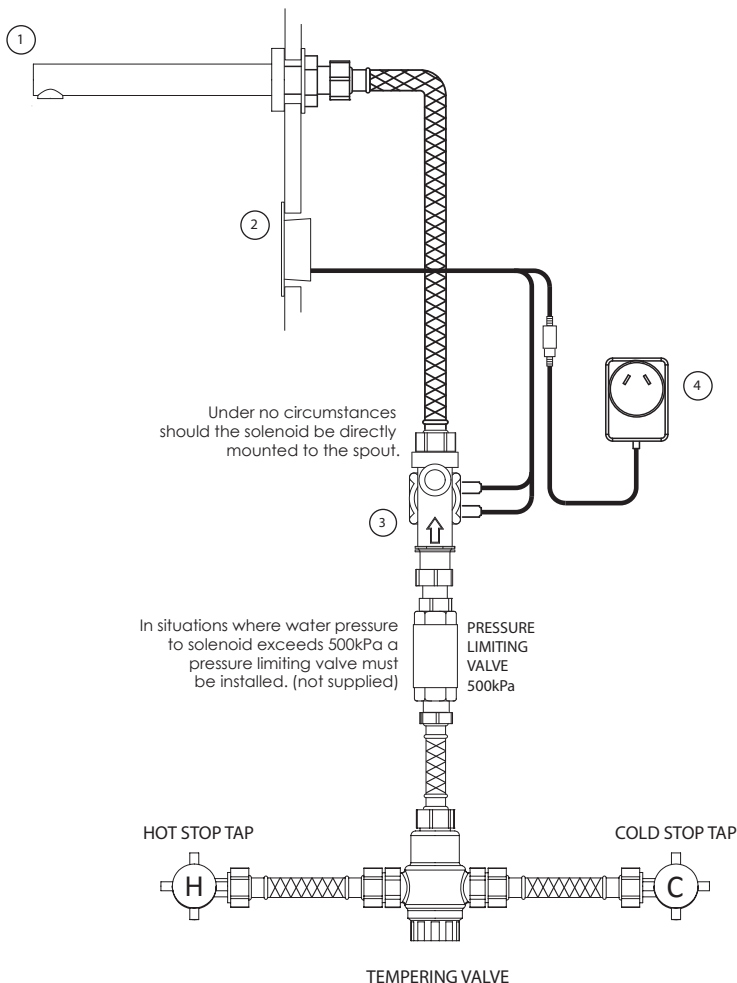

### COMPONENTS SUPPLIED

	Item Code	Description
1	300-0190	Wall mount Spout - straight
2	300-0185	Wall mount sensor
3	300-0183	24V AC Solenoid Valve
4	300-0124	24V Power Pack
5	300-3026	Sensor mounting kit



Autoflo Pty Ltd  
www.autoflo.com.au

Proudly distributed by



The Australian designed and manufactured, **Autoflo Wall Mount AA2-B** Mains Power Sensor Tap is suitable for hand-washing applications, particularly in the food service, hospitality and health industries where a reliable and affordable hands free sensor tap is of paramount importance for prevention of cross-contamination, hygiene and water saving.

The **Autoflo Wall Mount AA2-MH** is a built for purpose product, with clever features incorporated. The electronics are designed so the water flow is set to run for a period after the hands are removed from the sensor area, as is required in hospitals. The stainless steel sensor plate can simply be mounted to the wall using silicone. Adjustable sensor range and run-time ensure consistent performance in demanding environments.

## FEATURES

- Sensor range adjustable
- Run-time adjustment after hands are removed from sensor area
- Elegant chrome straight spout
- Stainless steel sensor plate
- Sensor operation indicator LED
- Power Pack operation indicator LED
- Removable solenoid filter basket
- Simple installation



**Order Code: 100-0178**

## TYPICAL DIMENSIONS

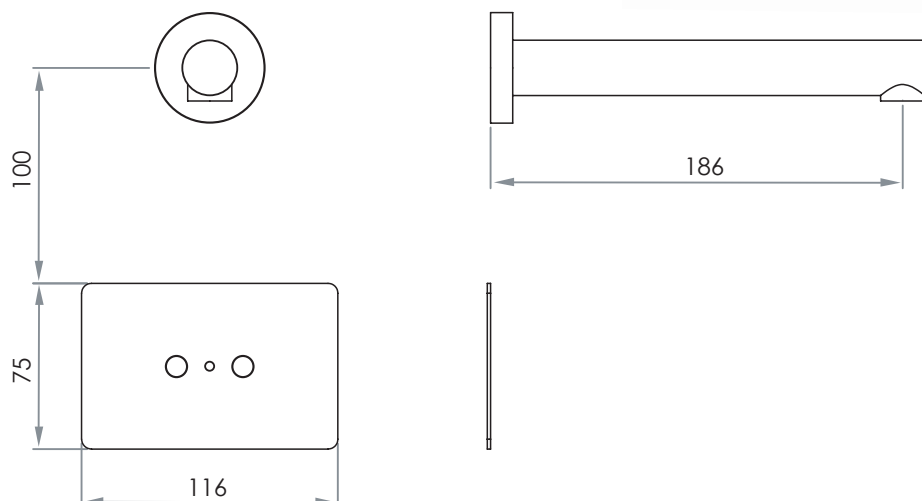

Every effort is made to ensure specifications are correct at the time of printing. Autoflo Pty Ltd reserves the right to make changes without prior notice. All measurements shown are in millimetres.

Proudly distributed by



## TECHNICAL SPECIFICATIONS

- SENSOR TYPE - Active Infrared
- SENSOR RANGE - 180mm factory set
- OPERATING SUPPLY - 24v AC Power Pack
- OPERATING PRESSURE - 50 to 500kPa
- RUN TIME - Max 15 seconds after hands removed
- FLOW RATING - 7 litres per minute
- SOLENOID - 24V
- MAX TEMPERATURE - 50°C



## TYPICAL INSTALLATION

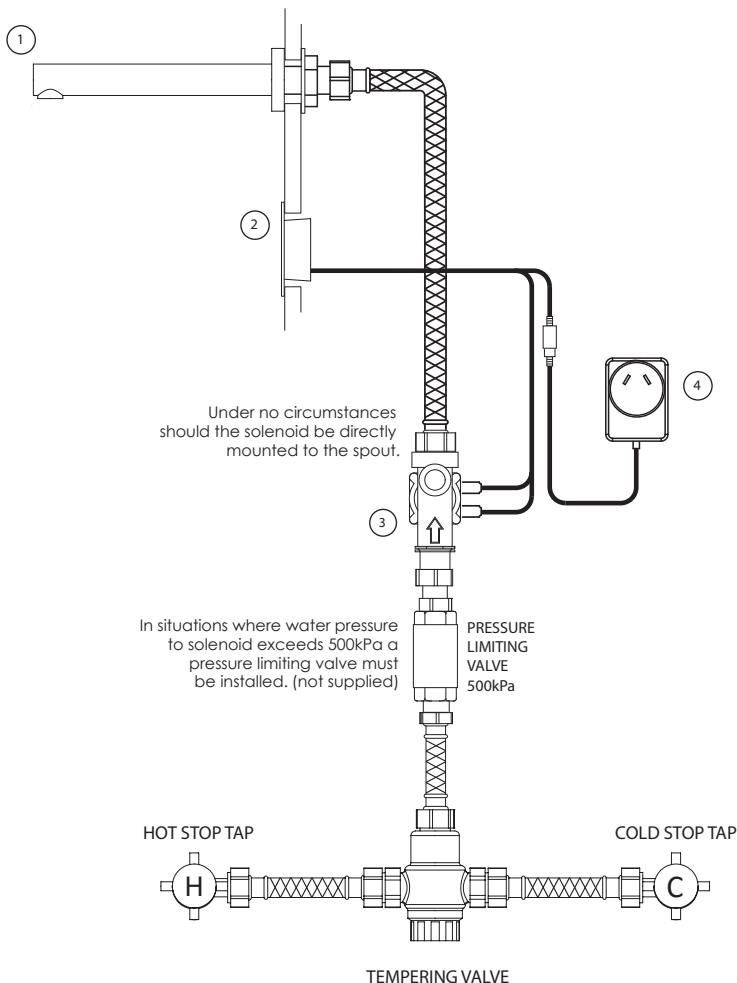

## COMPONENTS SUPPLIED

	Item Code	Description
1	300-0190	Wall mount Spout - straight
2	300-0185	Wall mount sensor
3	300-0183	24V AC Solenoid Valve
4	300-0124	24V Power Pack
5	300-3026	Sensor mounting kit



Autoflo Pty Ltd  
www.autoflo.com.au

Proudly distributed by

